

RE ♻️ STORE
RECYCLE
REDUCE
RECREATE



Top 3 British Design icons



- 1 Red Phone Box – 39%
- 2 Routemaster Double Decker Bus – 28%
- 3 Union Jack – 24%

Professor McDermott surveyed 2,000 adults in the UK and found that the Red Phone Box topped the list of designs symbolizing the UK.

10000 The number of K6 phone booth remaining.

31000 The number of K6 phone booth built.

These were once a feature of every high street in the country, but now number only 10,000 or so (and half of those are decorative rather than operational).



Recreate new value from No.1 british design icon

CONCEPT DESCRIPTION

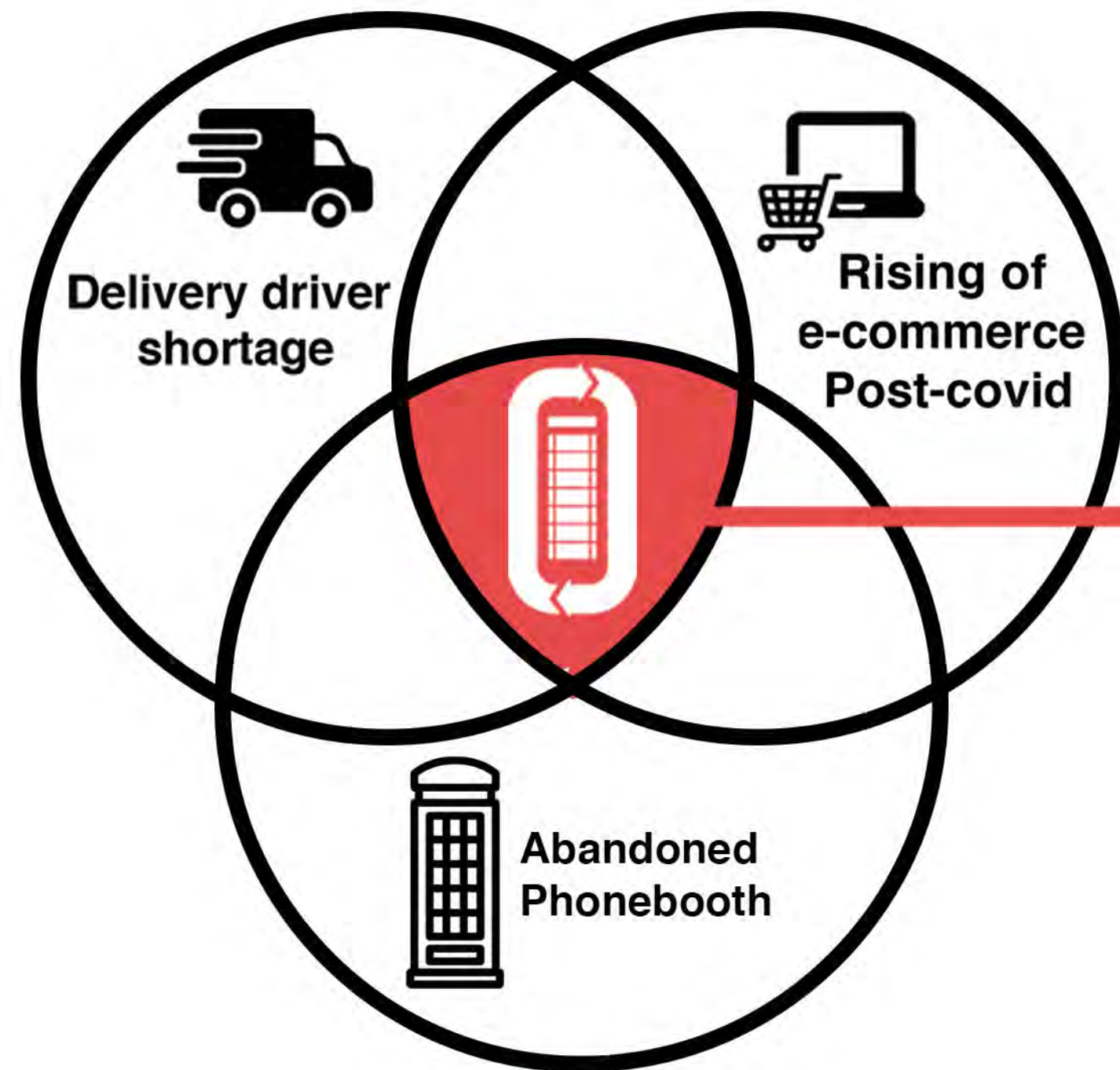

Solution



Sustainability



Efficiency



Design icon

My concept is to **recycle** these phone booths to become part of the delivery system. Currently existing delivery system require a lot of labor. and delivery robots to replace them are not designed for long-distance shipping. I am going to use the phone booth as a connection hub that connects this delivery van and delivery robots. It is a way to benefit **economically** and environmentally by **recycling the existing infrastructure**. In addition, **London's heritage** can be emphasized by keeping the cultural icon of the red phone booth.

Phonebooth
Charity
Foundation

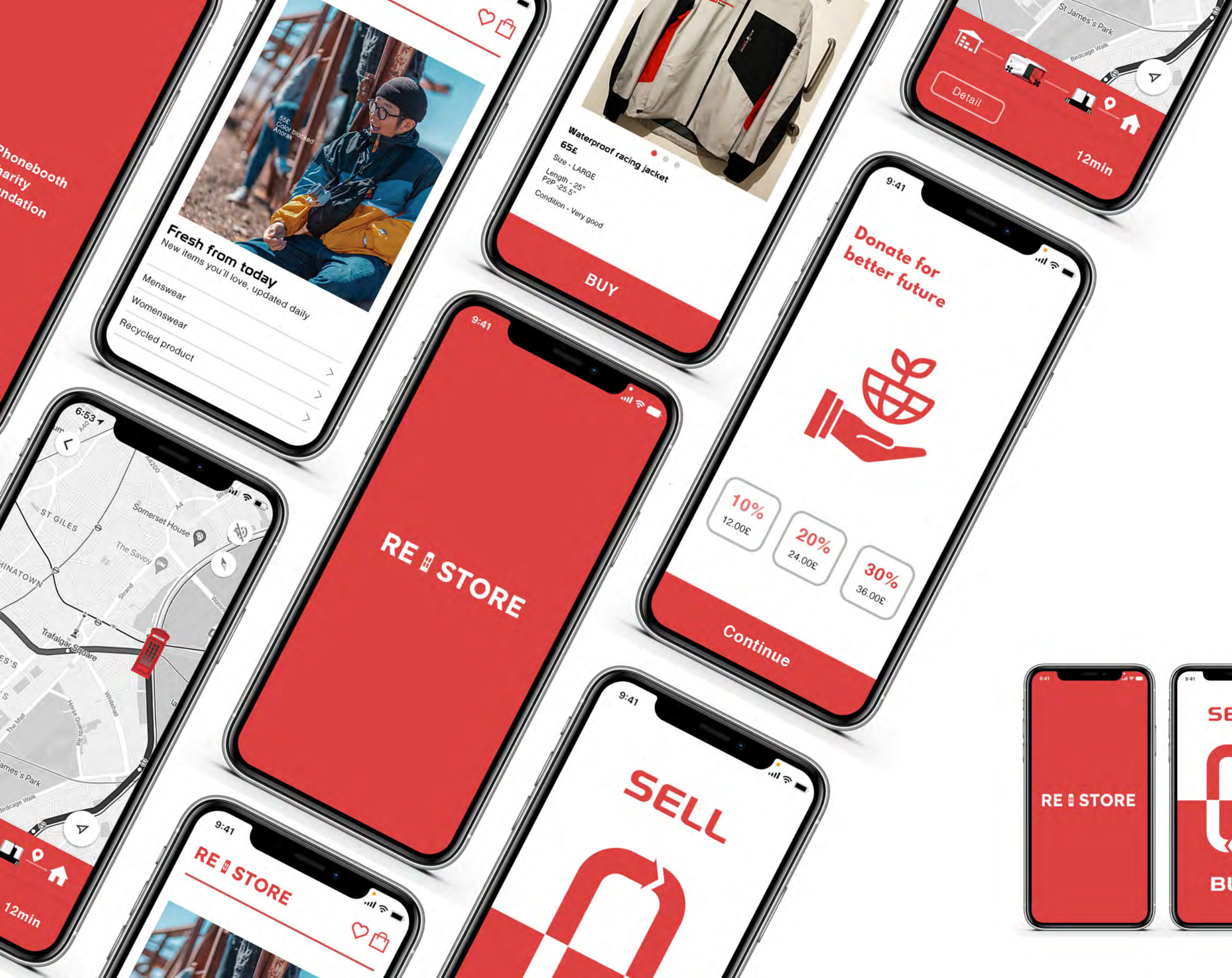

RE:STORE

RECYCLE
REDUCE
RECREATE

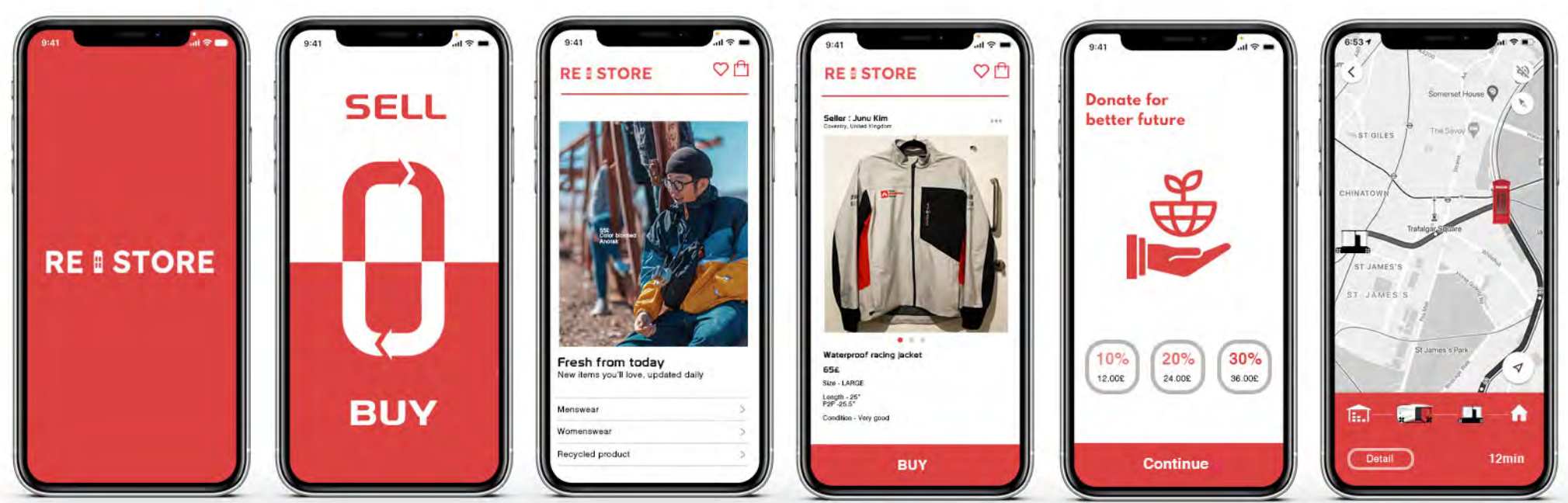



Revival of London's Icon

My concept is to recycle these phone booths to become part of the delivery system. Currently, existing delivery system require a lot of labor, and delivery robots to replace them are not designed for long-distance shipping. I am going to use the phone booth as a connection hub that connects this delivery van and delivery robots. It is a way to benefit economically and environmentally by **recycling the existing infrastructure**. In addition, **London's heritage** can be emphasized by keeping the **cultural icon** of the red phone booth.

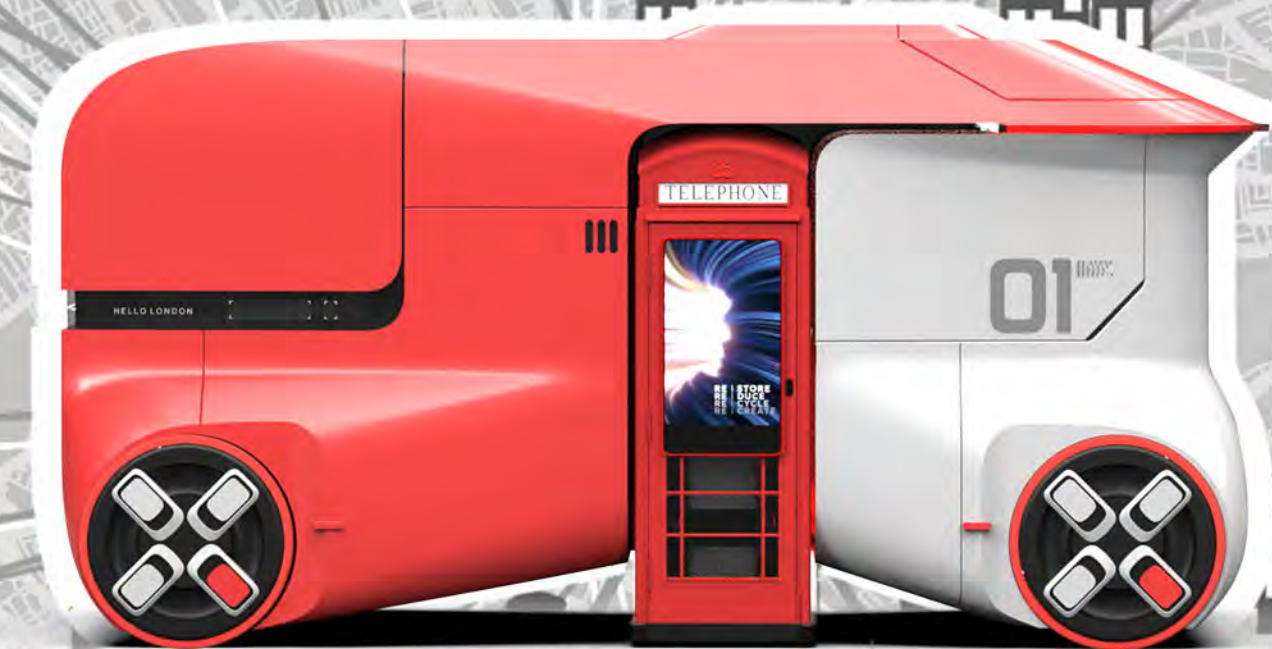

10000 The number of
K6 phone booth remaining.

31000 The number of
K6 phone booth built.

These were once a feature of every high street in the country, but now number only 10,000 or so (and half of those are decorative rather than operational).

Customer



Jessica

Age: 27

Reidential : London

Job : Writer

Character : Calm, Emotinal

Salary : 3100 GBP



Jessica is a best-selling novel writer who succeeded at a young age. She is currently 27 years old and was born in Bournemouth and has lived alone in London for eight years. She usually spend most of her free time at home enjoying a **calm and emotional atmosphere**. She is a vintage goods collector and mainly purchases goods from eBay or portobello markets. Painting is a her hobby. She enjoy visiting many art galleries in London.

PERSONA



Worker

David

Age: 33

Reidential : London

Job : Delivery hub manager

Character : Active, Rational

Salary : 2500 GBP

David works as a manager at a delivery hub. He is 33 years old and was born in London and lives to this day. He has an active and rational personality. It has a good reputation for efficient work. Balance between work and life are important to him. As an **early adopter**, he always enjoys encountering new technologies. Hobbies are video games and soccer.

Visitors & Citizens



Not only Londoners but also visitors to London are affected by the project. **The new urban landscape of London that this project will change will give visitors a different experience.**





= DELIVERY HUB

TELEPHONE

Docking
Charging
Managing

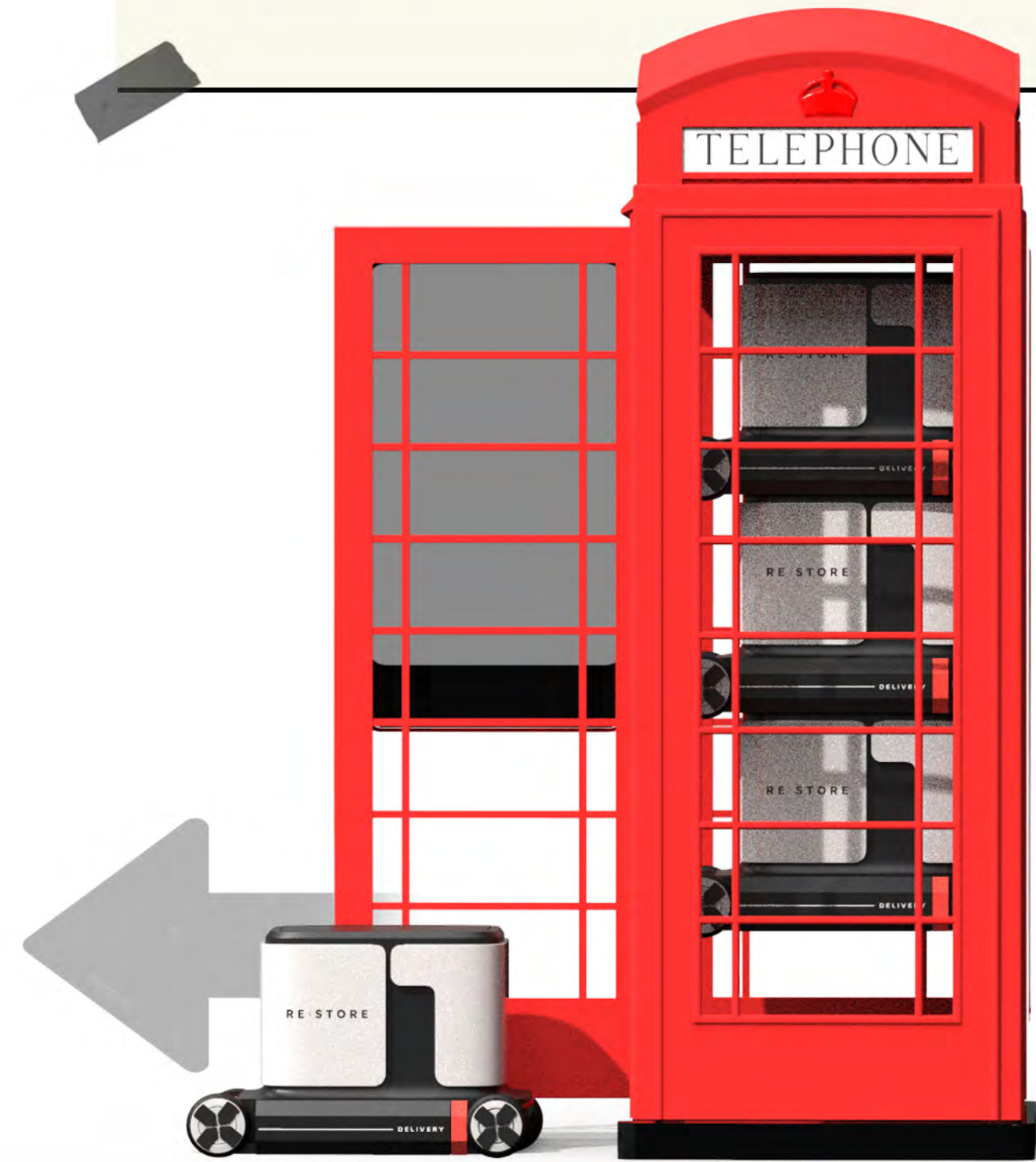

Delivery system
with
Recycled infrastructure



Full - Automatic system by conveyor belt & rail

INTERIOR LAYOUT

This is **unmanned delivery vehicle** with Level 5 autonomous technology. Therefore, the inner space of this vehicle **doesn't require interior space for human**.

The parcels in the vehicle are moved from LCV to robot by conveyor belt.

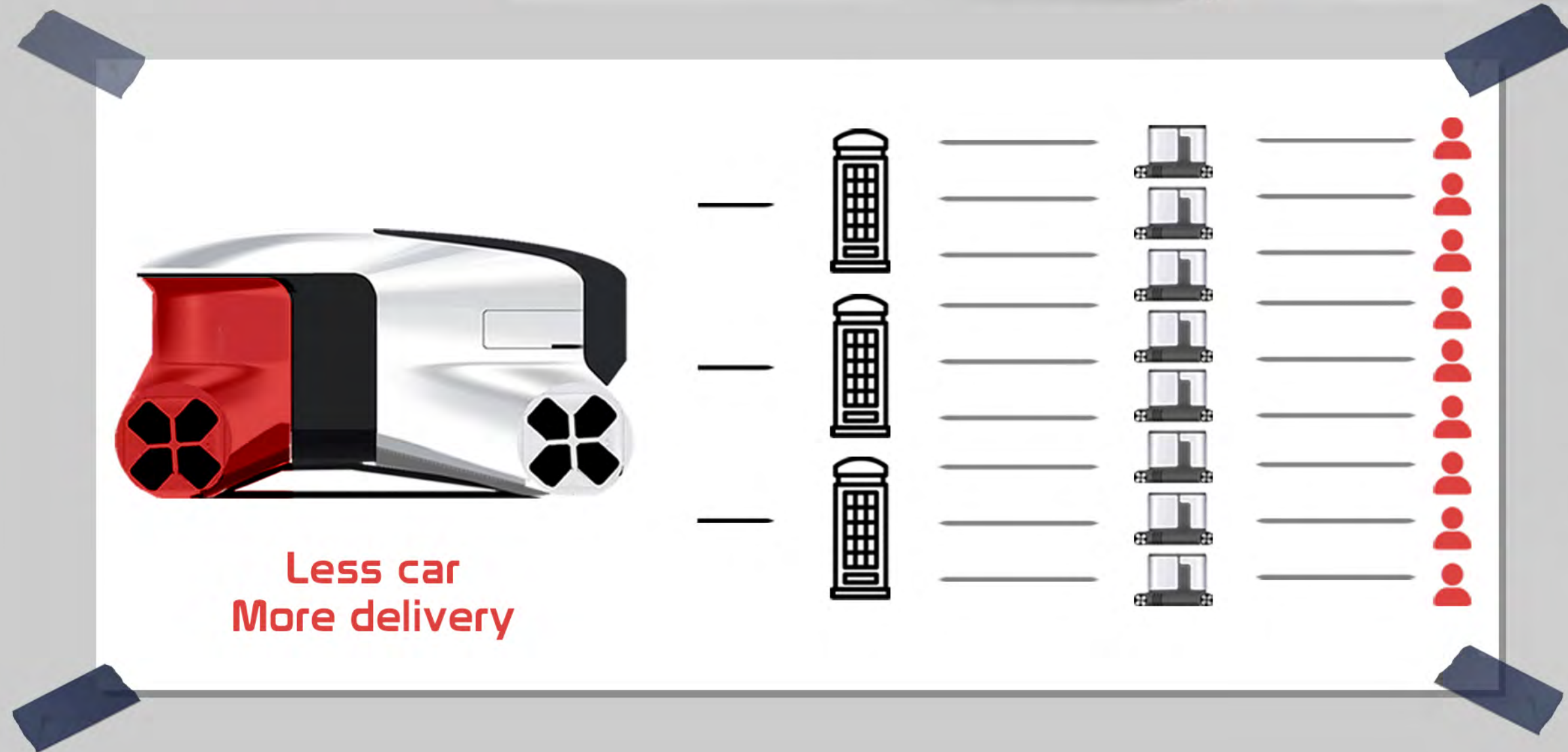
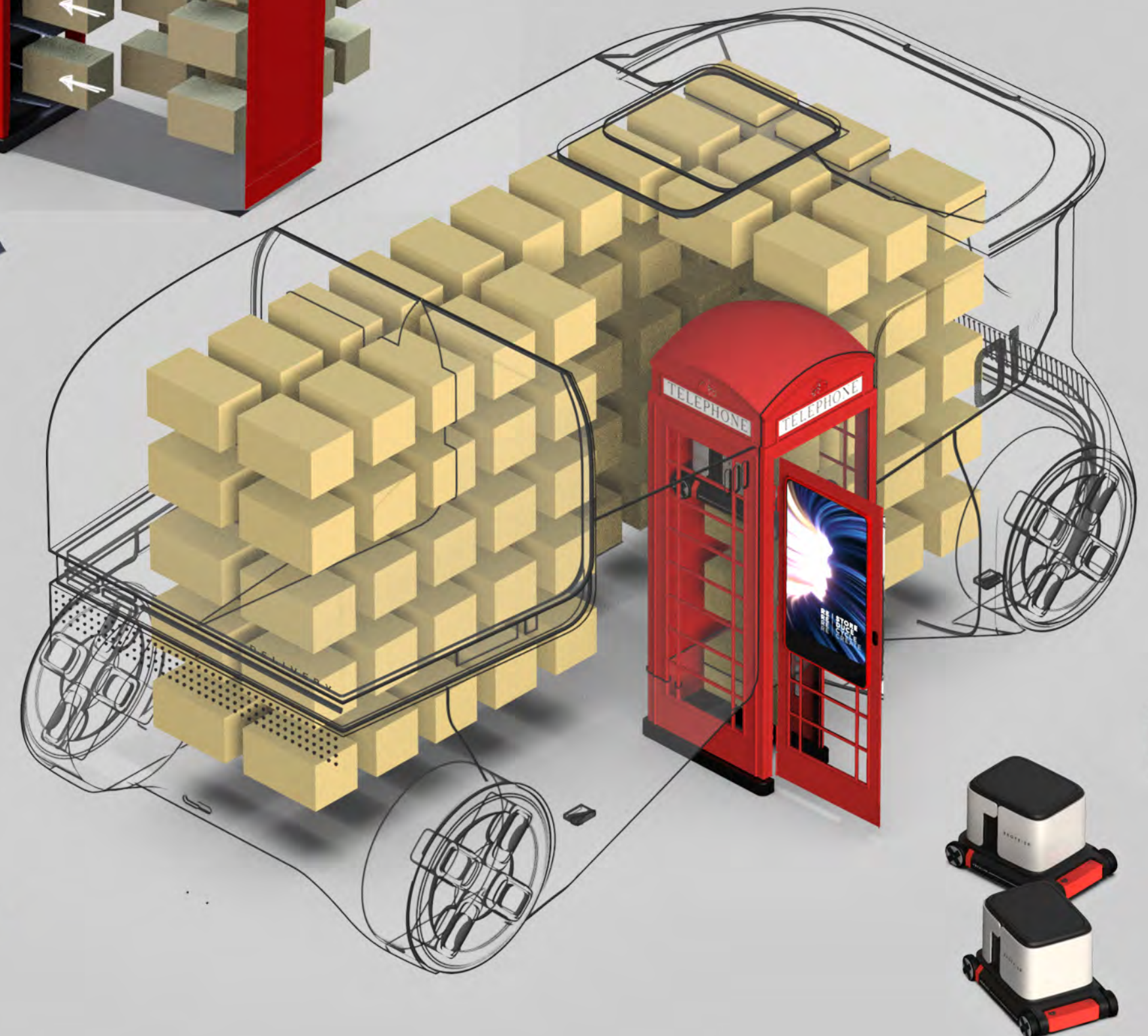
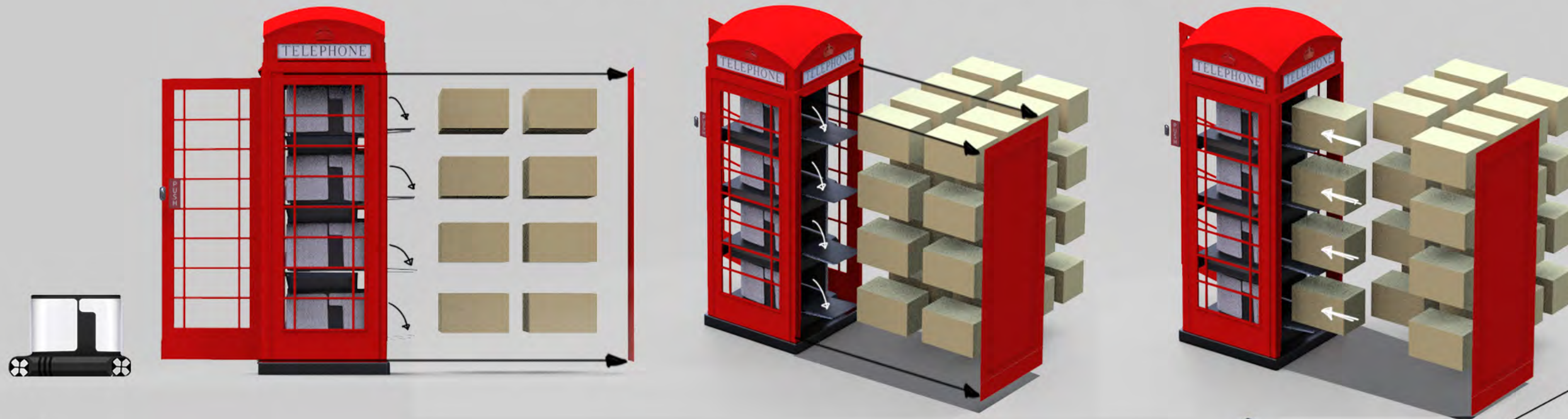

Less car
More delivery

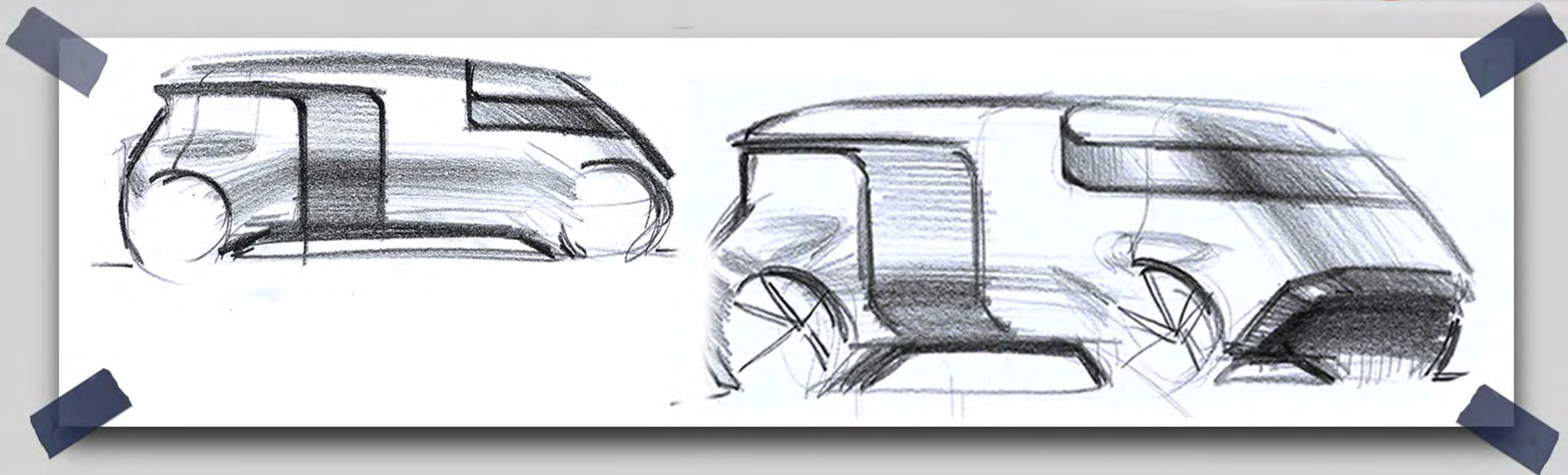
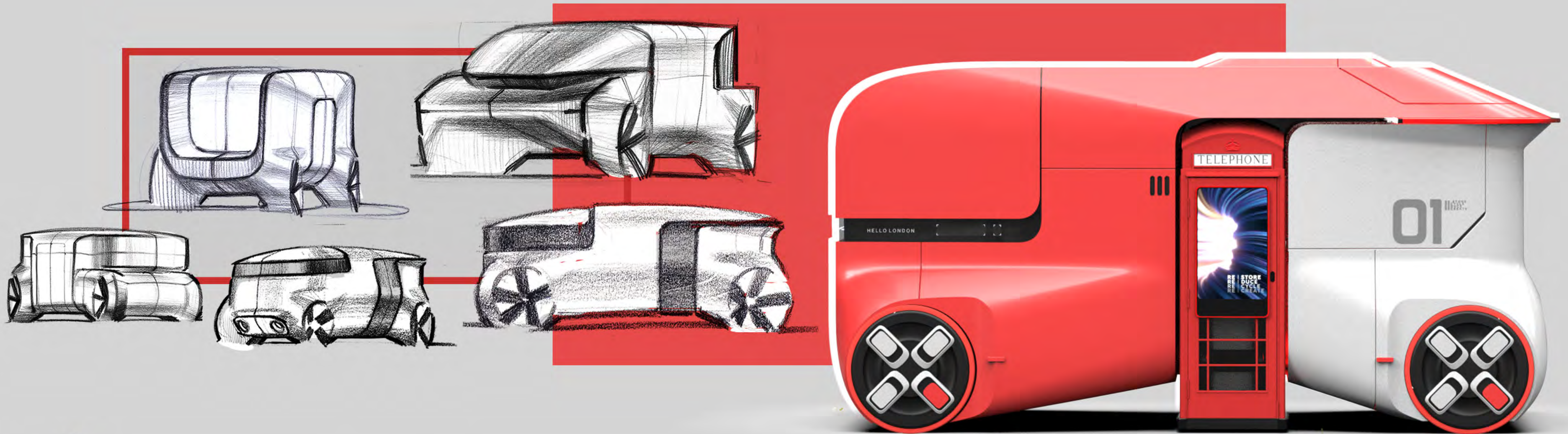

DESIGN PRINCIPLE |

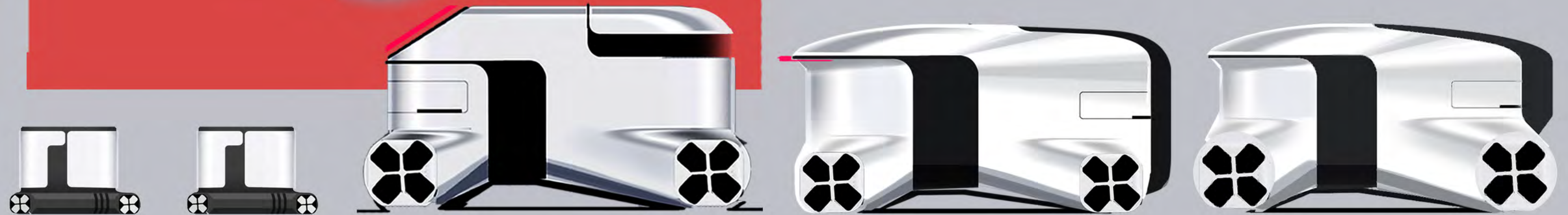
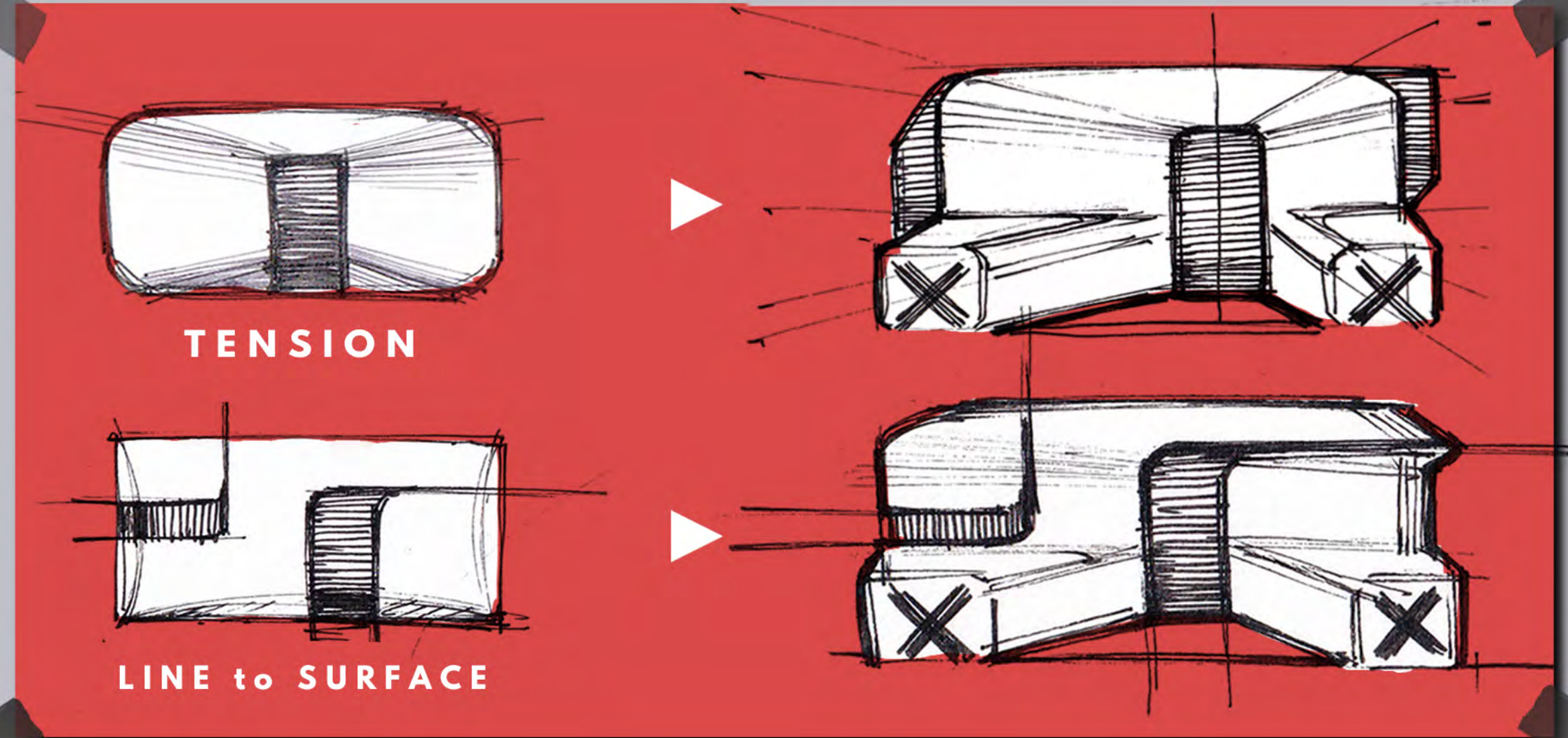
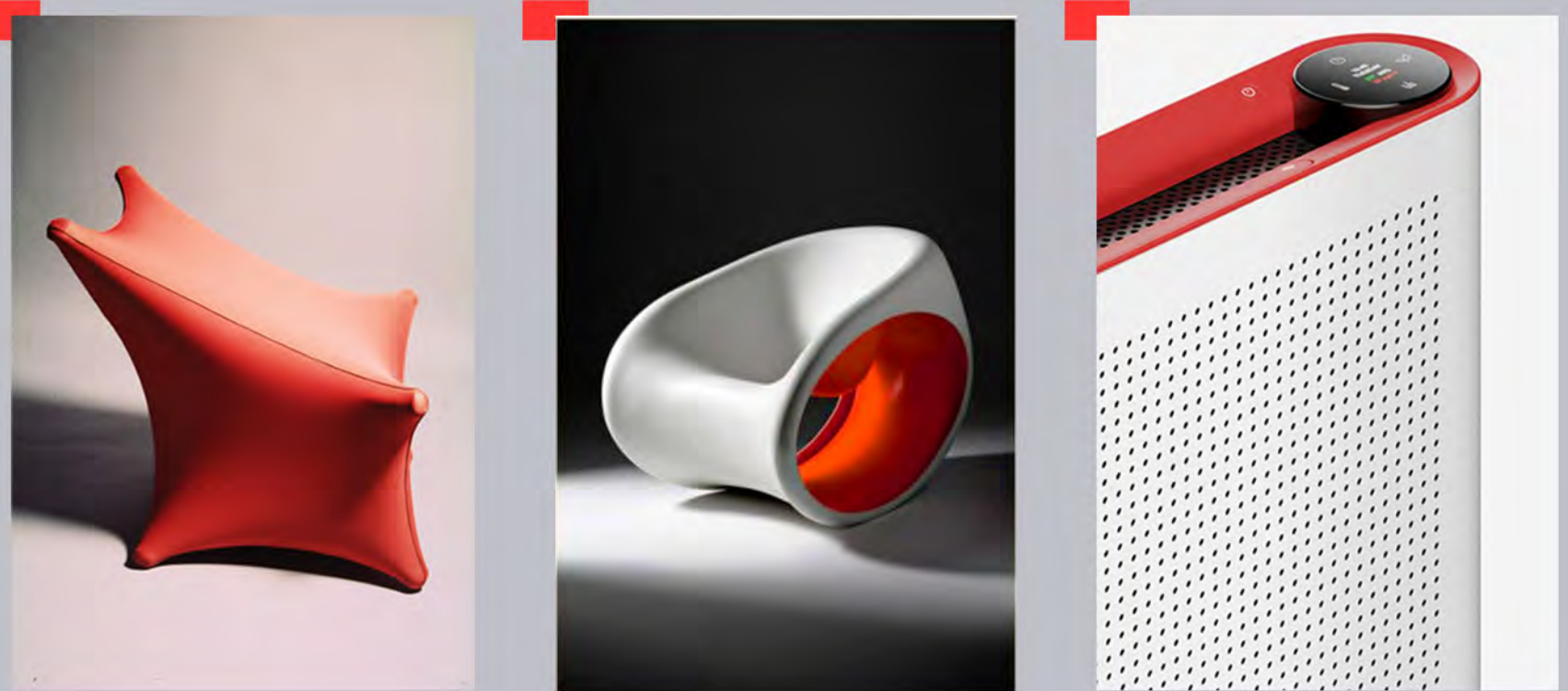

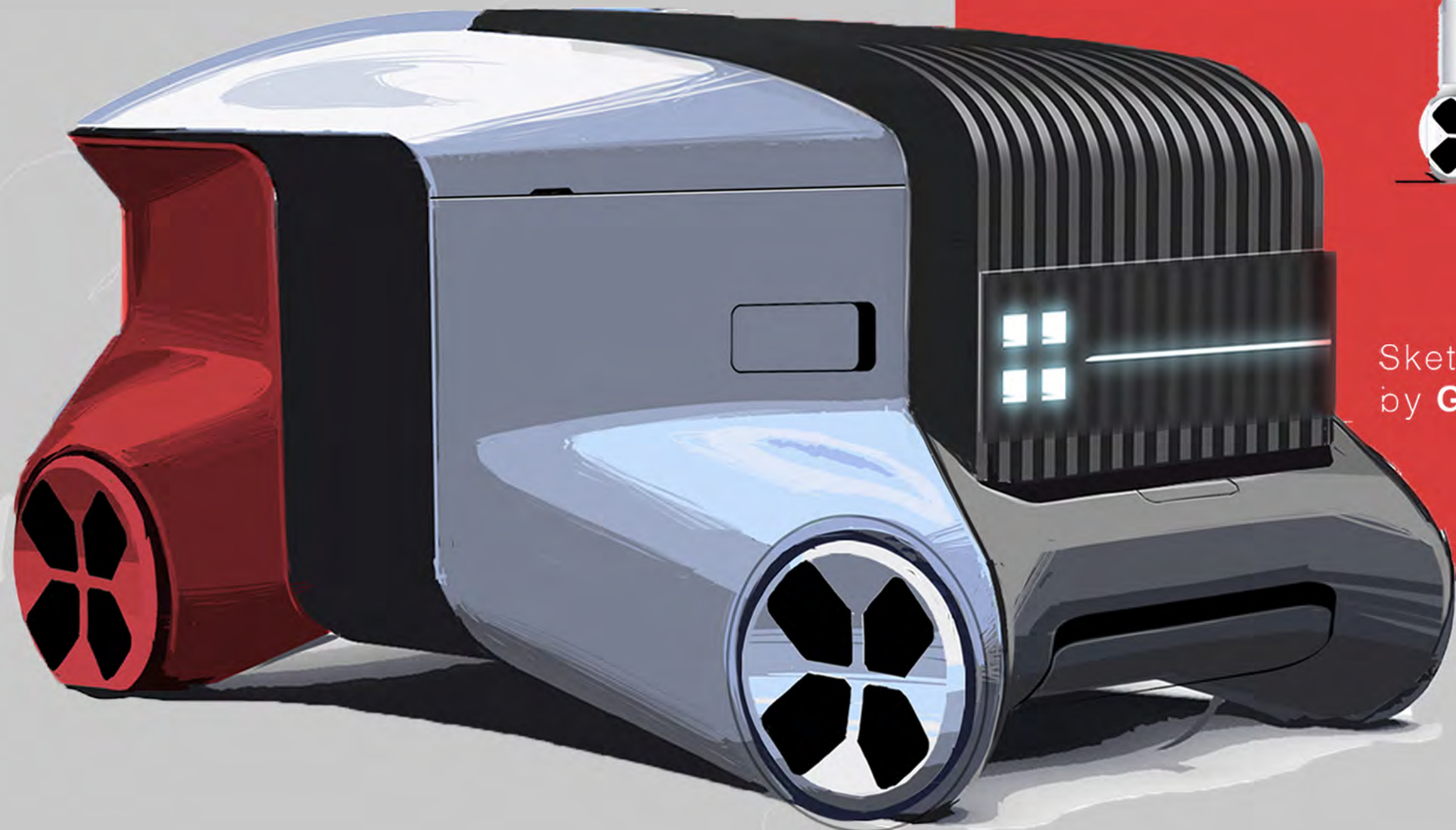
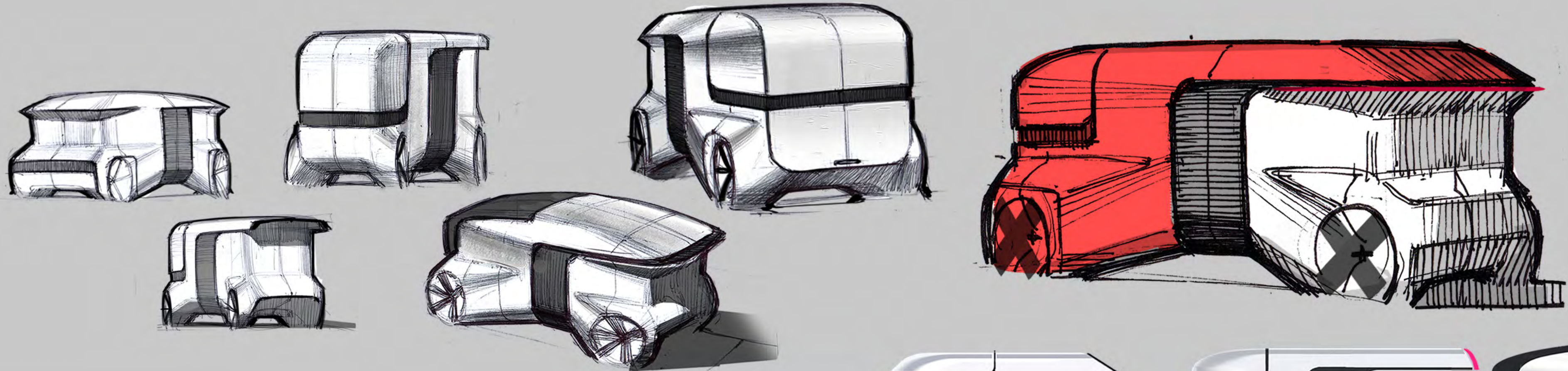

Sketch model
by Gravity sketch

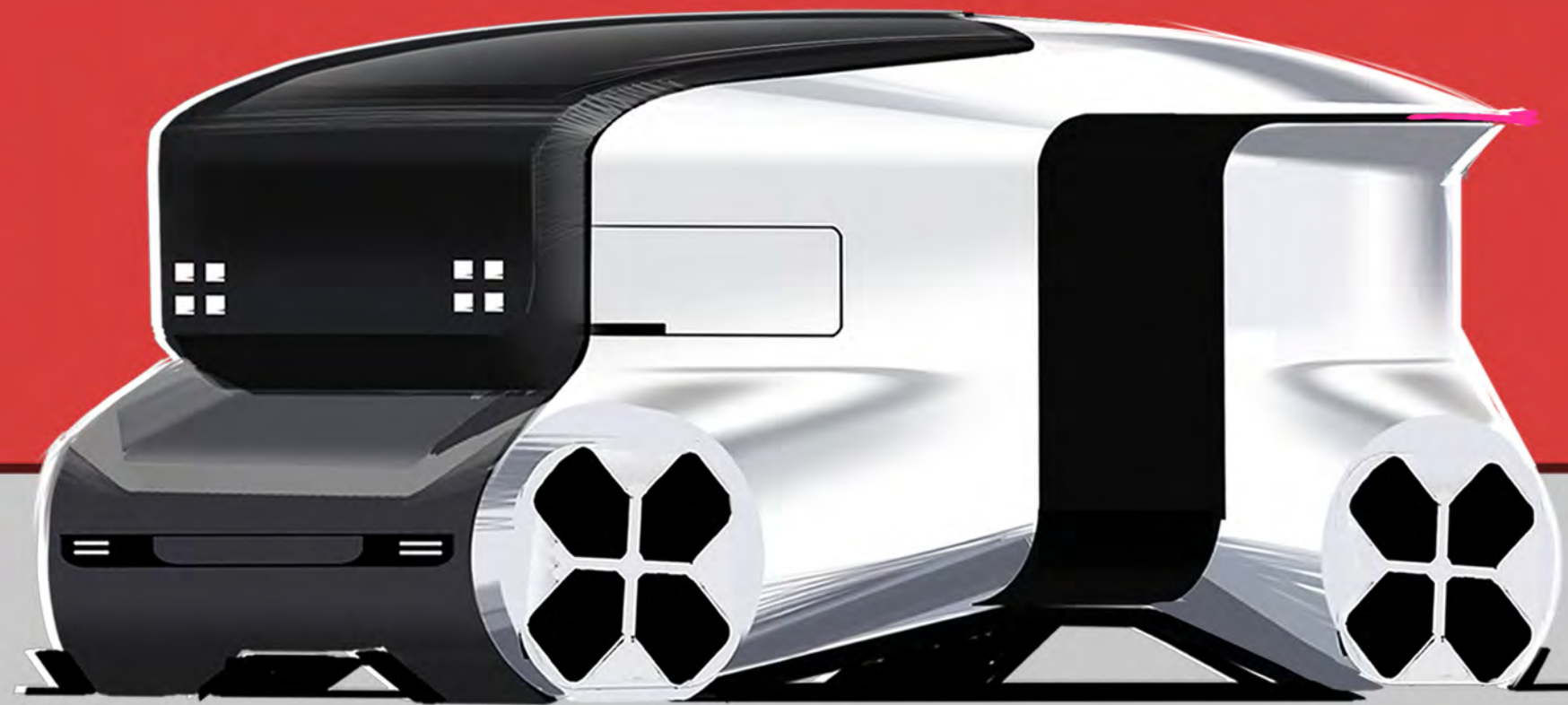

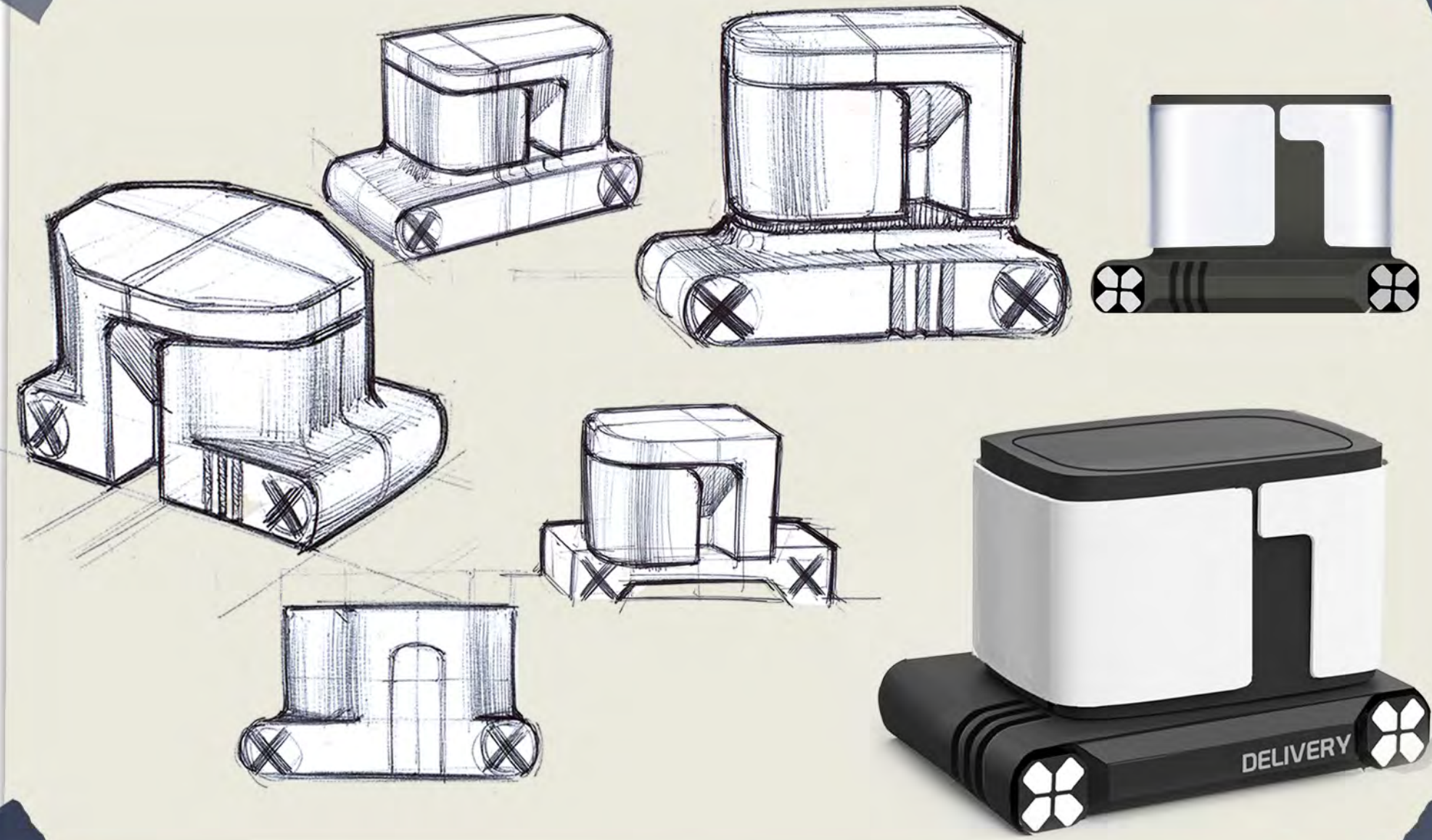

DELIVERY ROBOT DESIGN

Emergency!



Each delivery robot has AED for emergency situation. When cardiac arrest patient has been reported, the nearest delivery robot will deliver AED kit immediately.



AED
Automated External Defibrillator



Iconic head lamp

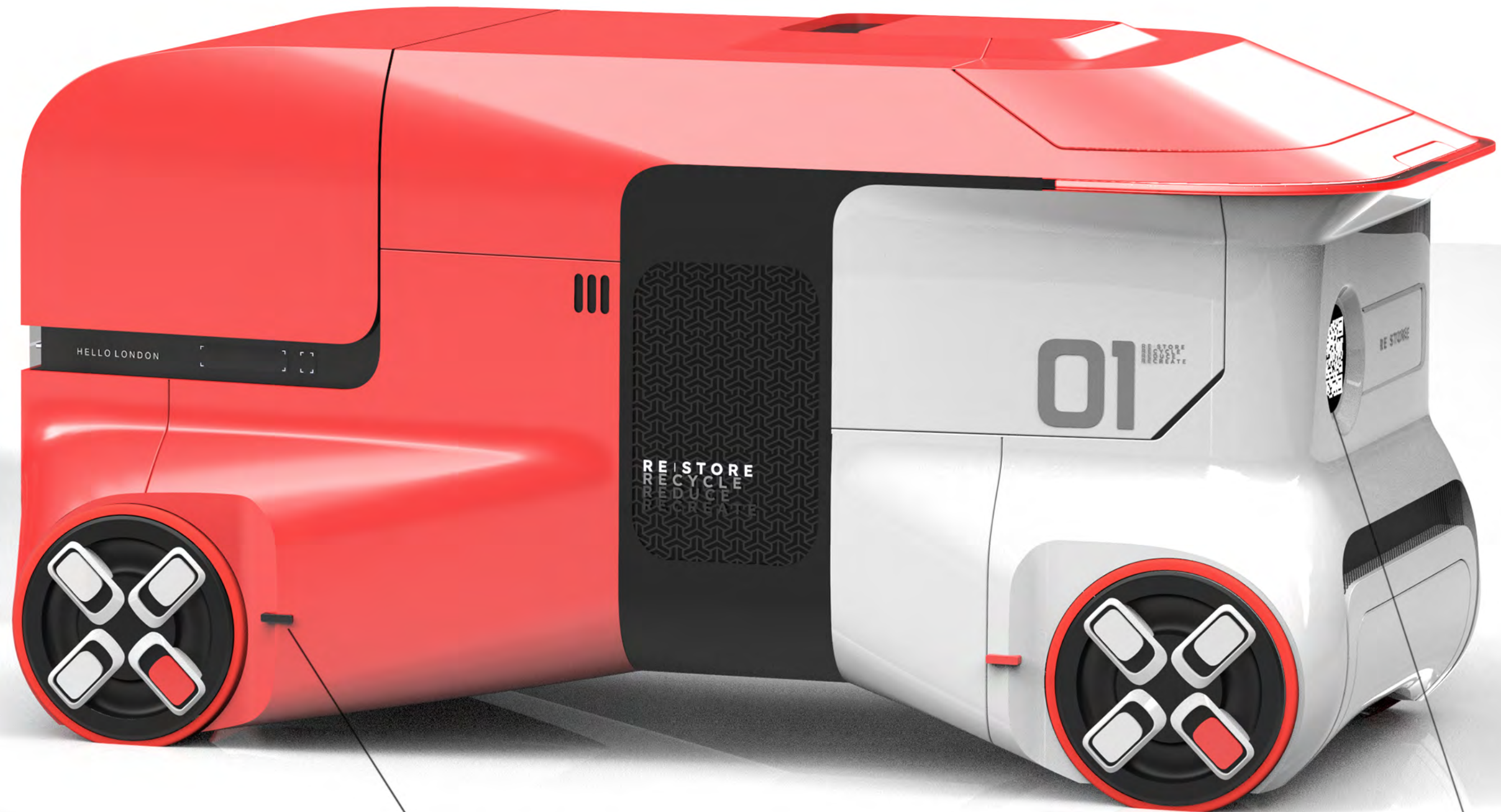

Camera sensor

QR code display for app advertisement

THE NEW ICON OF LONDON

Basically, this is **unmanned vehicle** with full autonomous technology. Because of this feature this vehicle has **unique face without glass greenhouse**.

PACKAGE DRAWING

Design specification

Battery : 600 volt (15-80% -34 min)
Battery configuration : Li-ion, single battery pack
Peak power : Targeting 286hp
Maximum capacity : 2.25 tons
Delivery range : 280 miles
Power dose :87kwh
Length : 5650mm
Width :2920m m
Height : 2930mm (Red phone booth's height : 2.4m)
Cost : 31500 GBP
Autonomous : Level 5

Top view

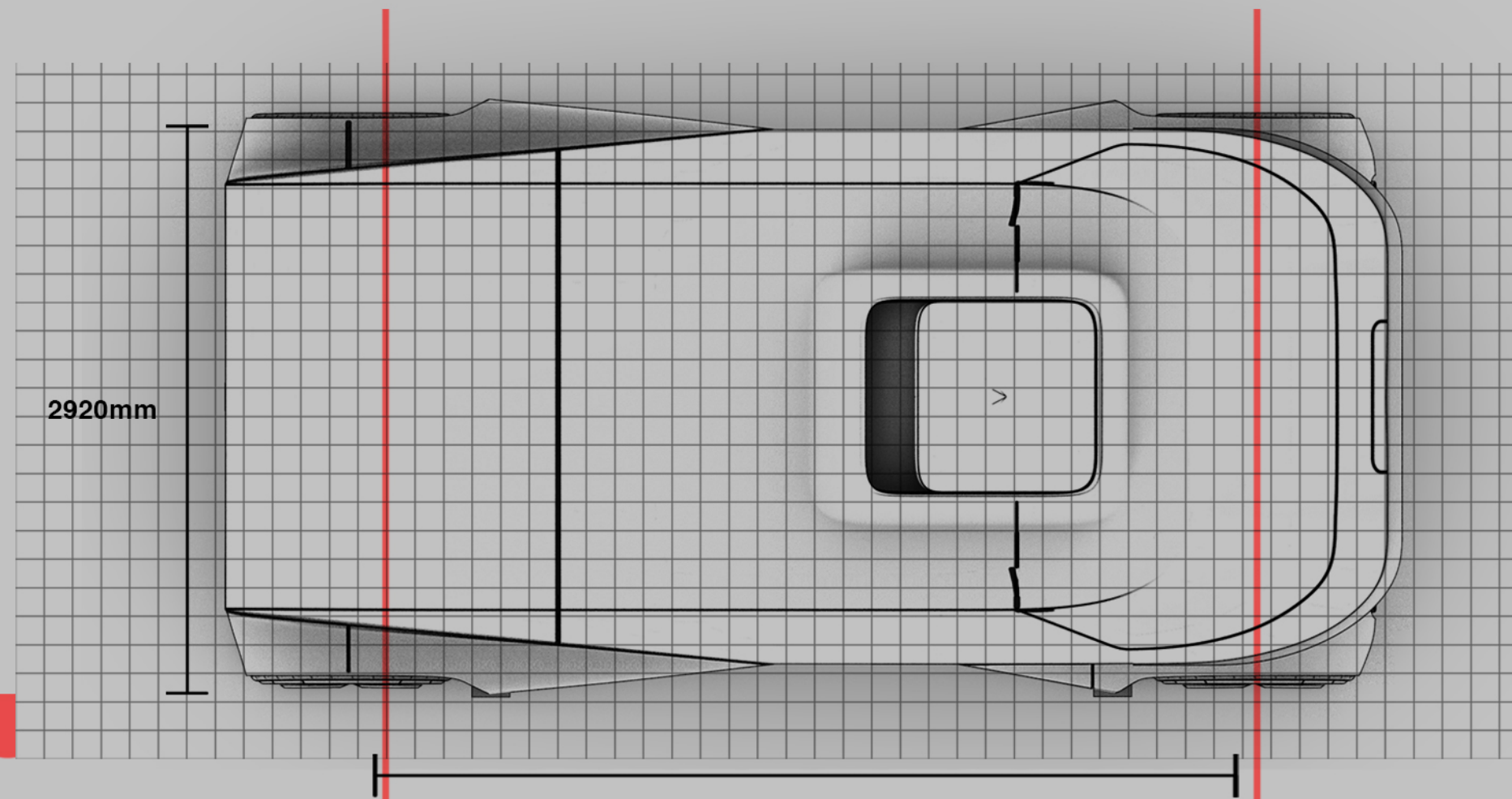

Front view

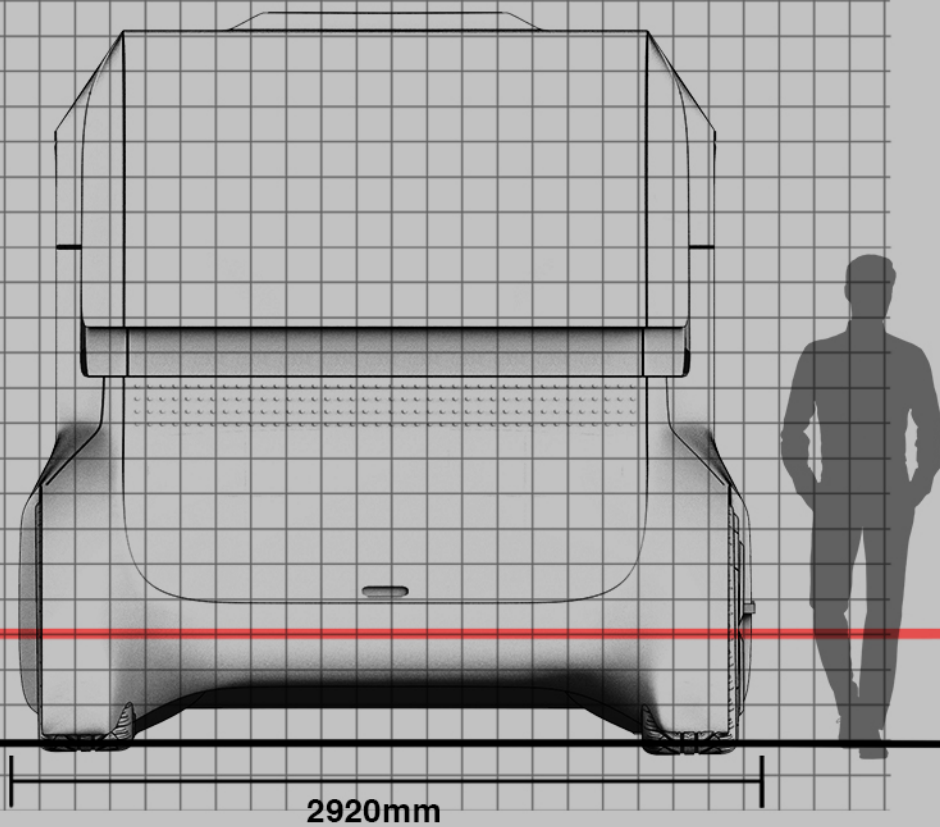

Side view

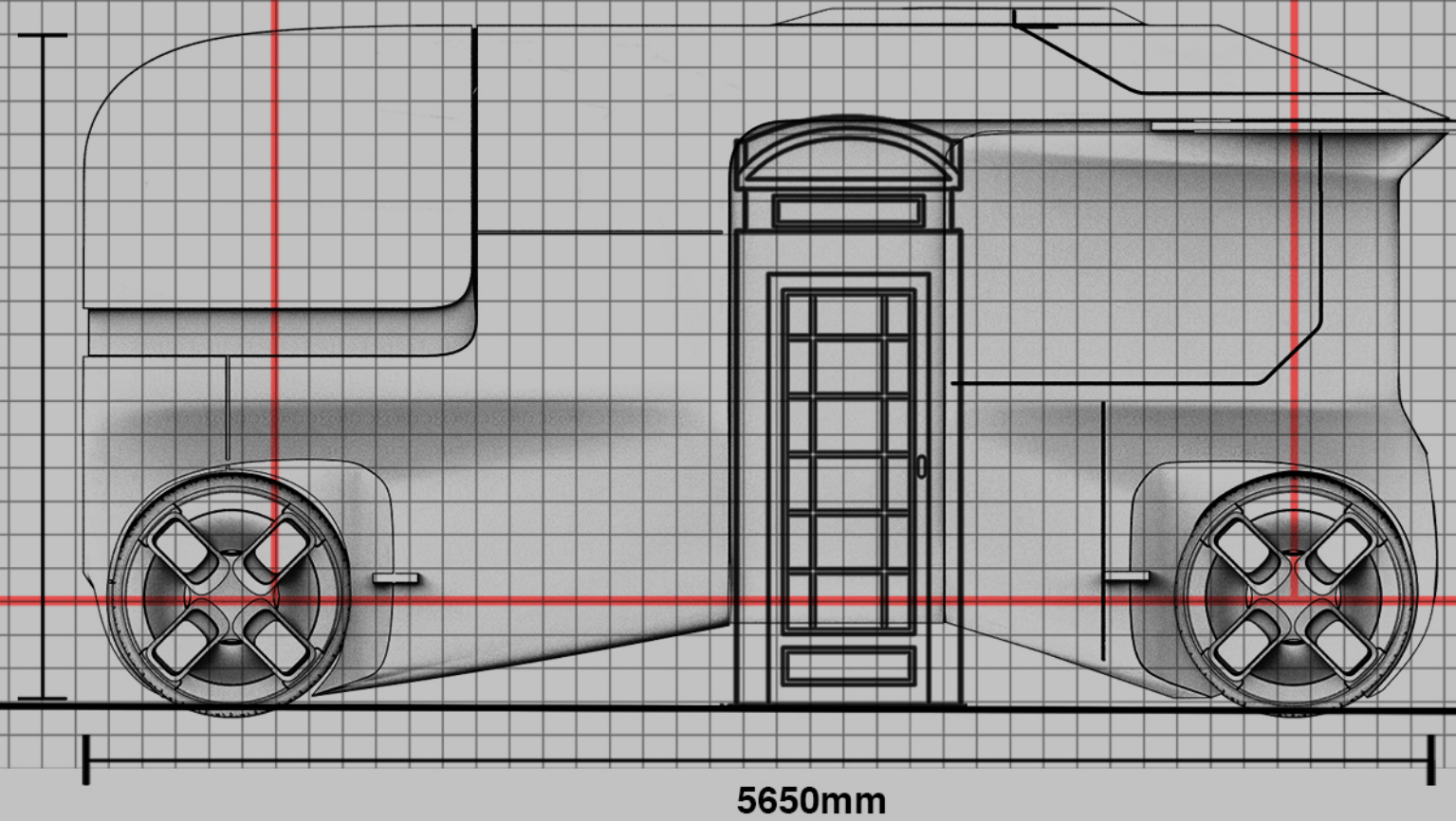

Rear view

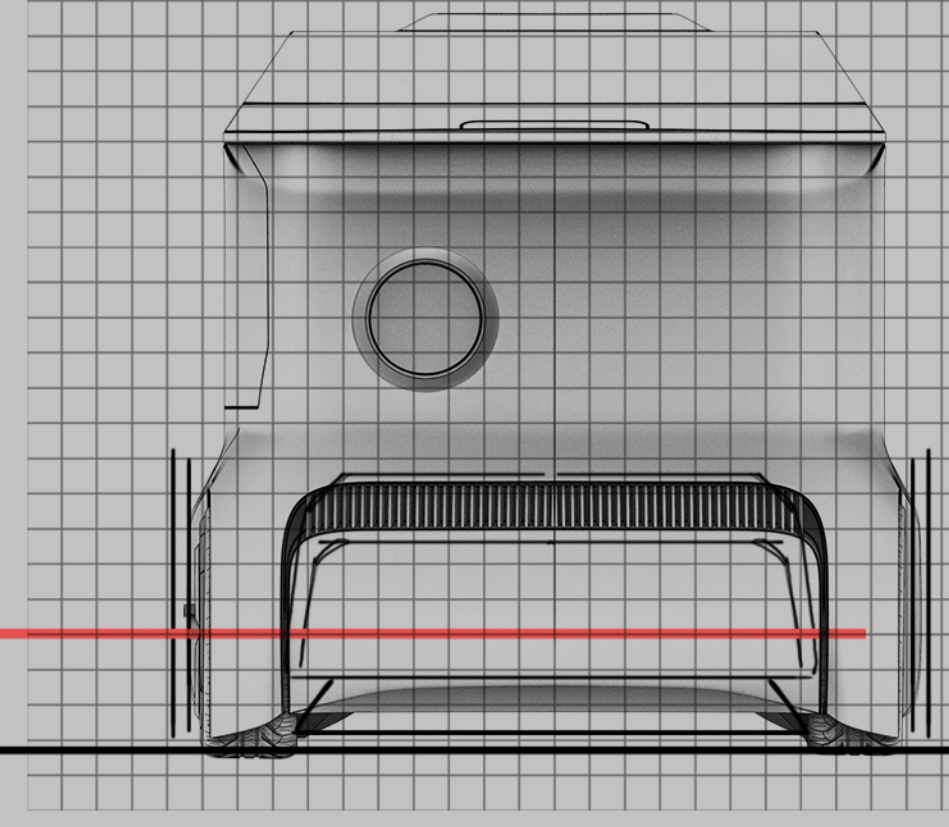

PACKAGE DRAWING

Design specification

Battery : 600 volt (15-80% -34 min)
Battery configuration : Li-ion, single battery pack
Peak power : Targeting 286hp
Maximum capacity : 2.25 tons
Delivery range : 280 miles
Power dose : 87kwh
Length : 5650mm
Width : 2920m m
Height : 2930mm (Red phone booth's height : 2.4m)
Cost : 31500 GBP
Autonomous : Level 5

Top view

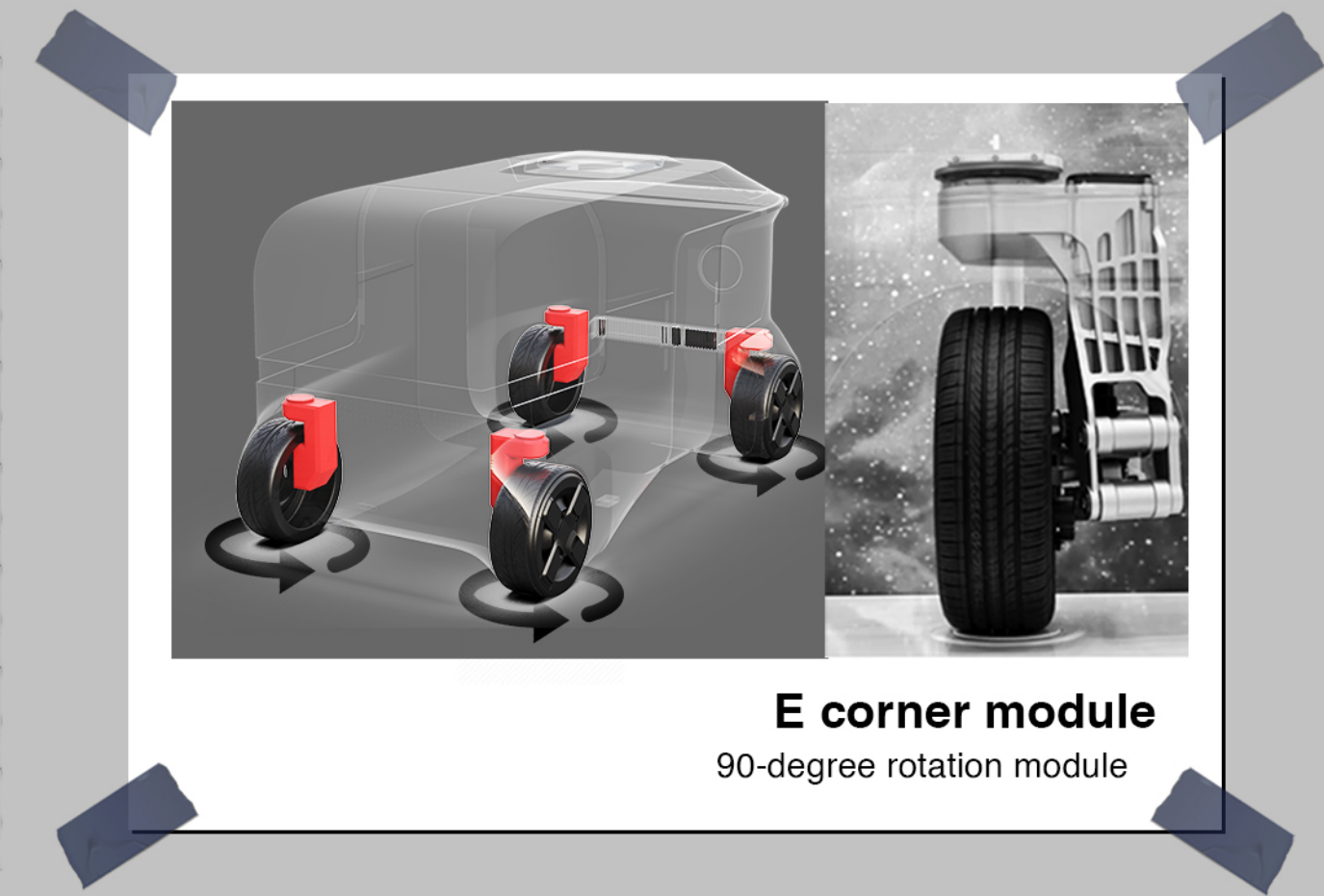
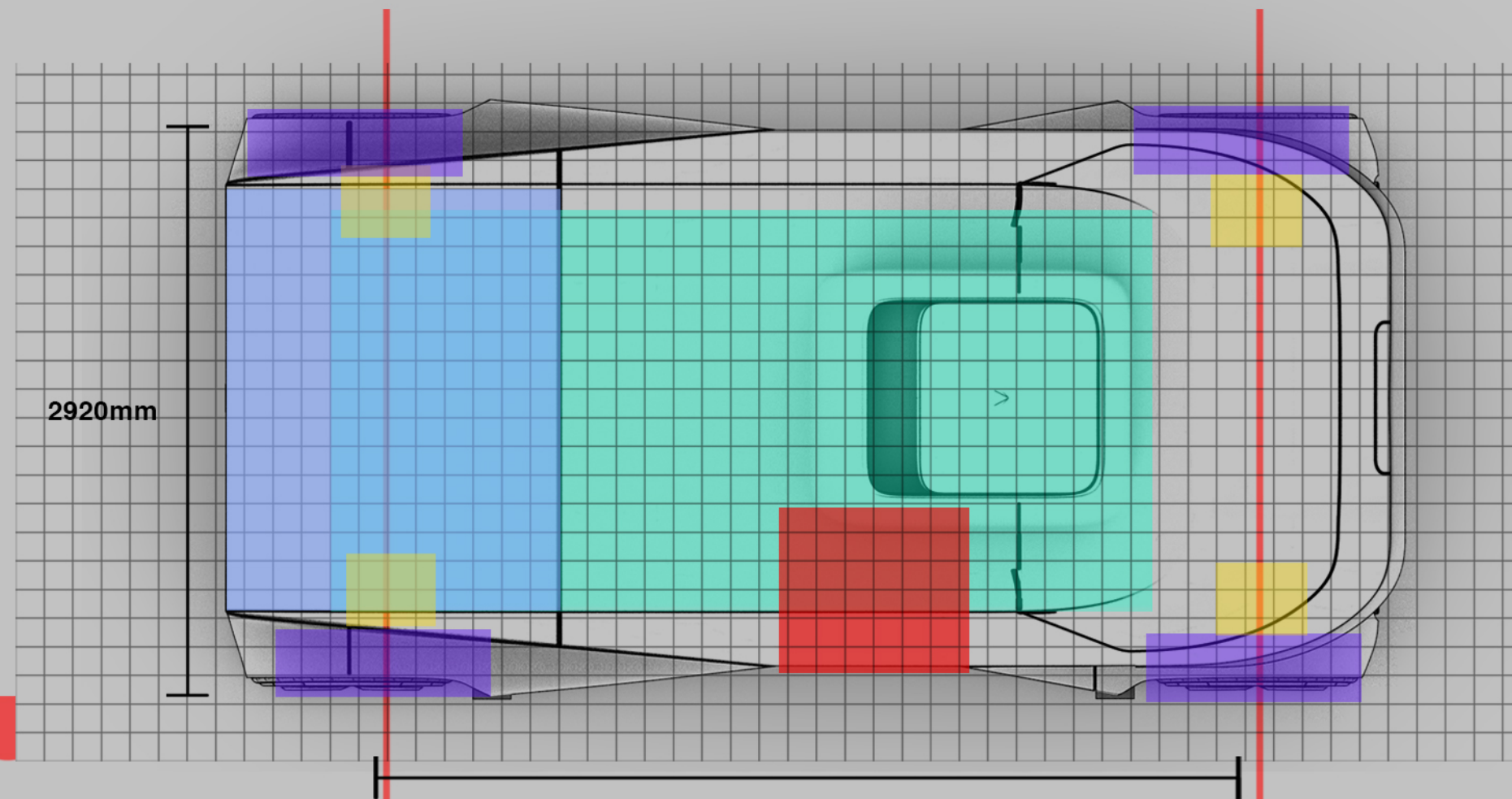

Front view

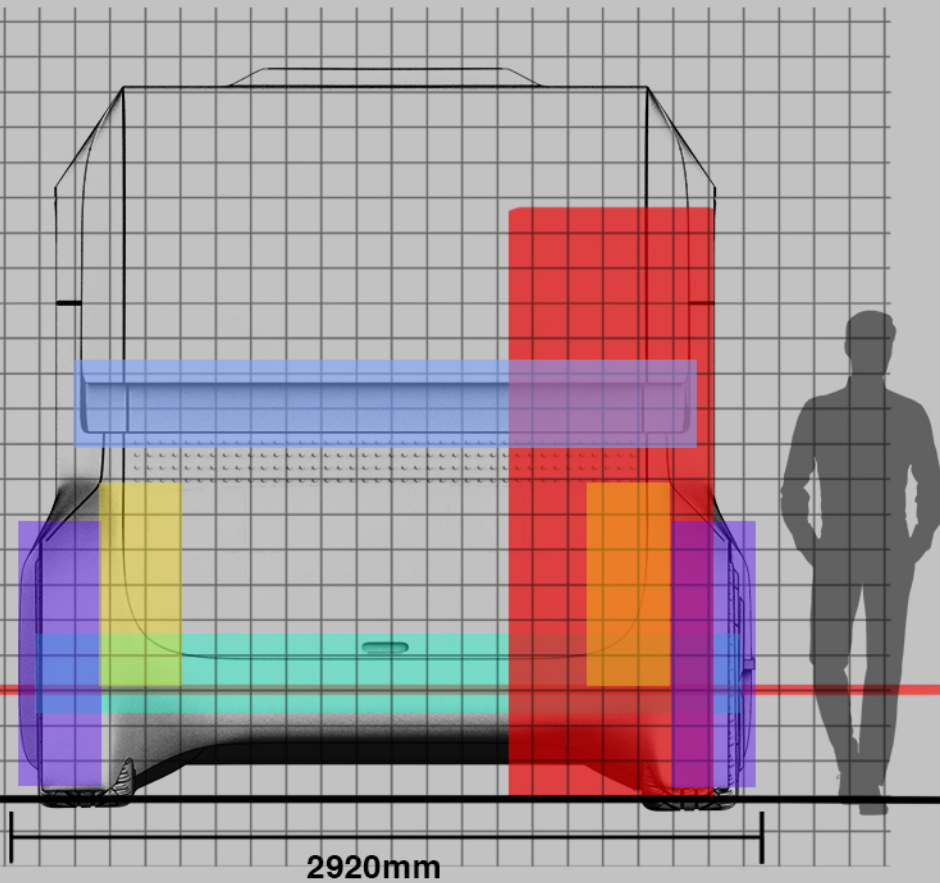

Side view

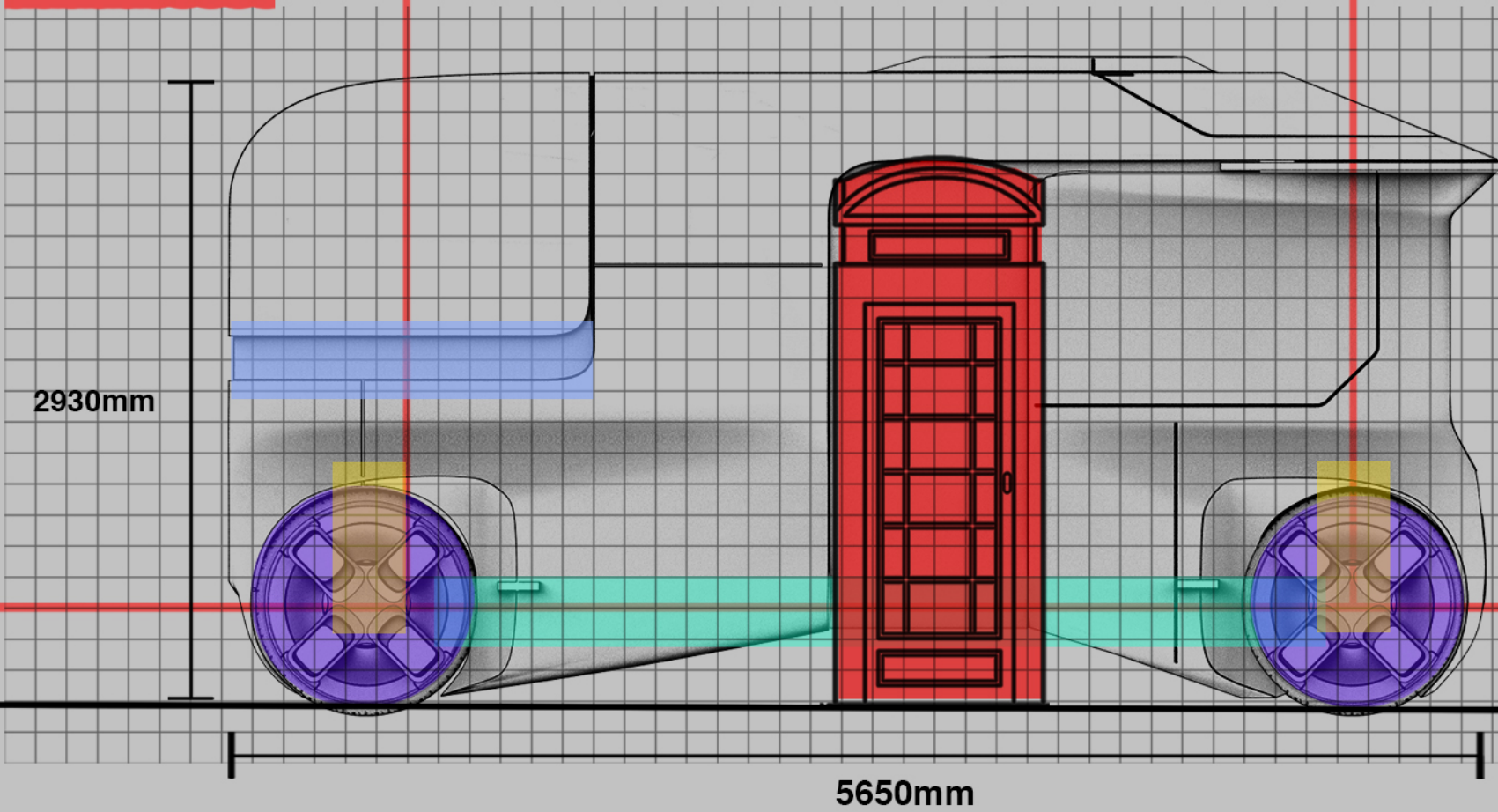

Rear view

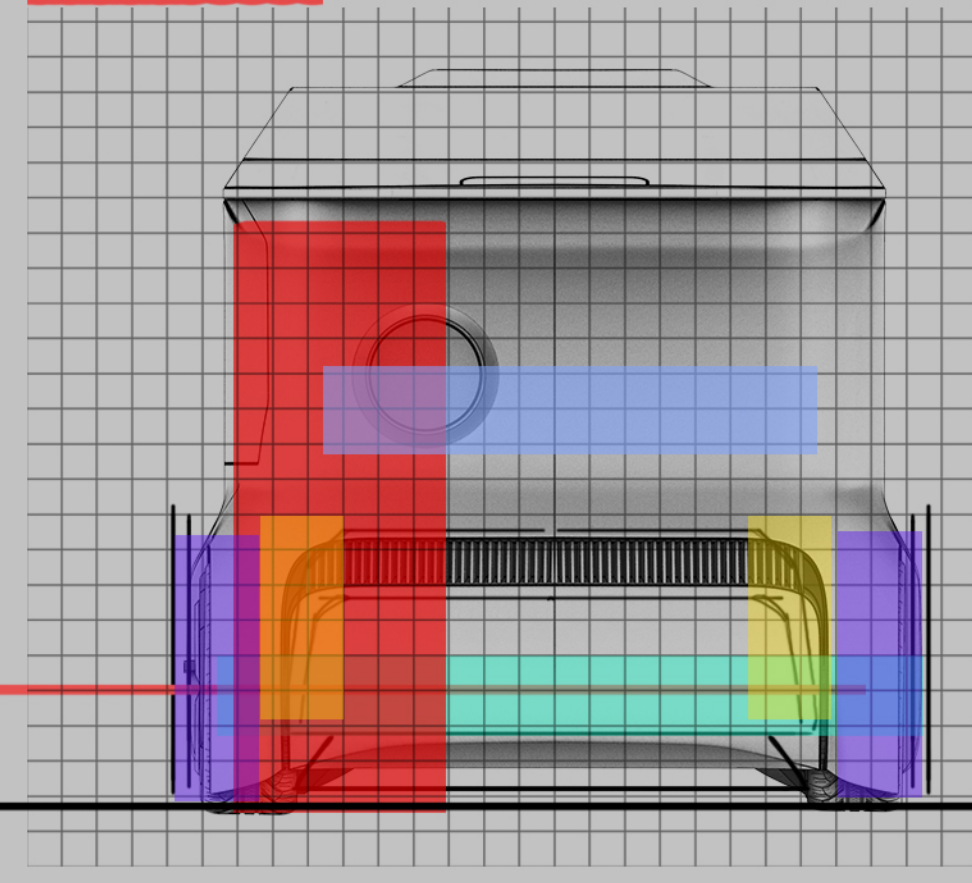

- Sensors & computer
- Cargo space
- Battery
- Red phone booth
- Electric motor
- E-corner module

PACKAGE DRAWING

Design specification

Battery : 600 volt (15-80% -34 min)
Battery configuration : Li-ion, single battery pack
Peak power : Targeting 286hp
Maximum capacity : 2.25 tons
Delivery range : 280 miles
Power dose : 87kwh
Length : 5650mm
Width : 2920m m
Height : 2930mm (Red phone booth's height : 2.4m)
Cost : 31500 GBP
Autonomous : Level 5

Top view

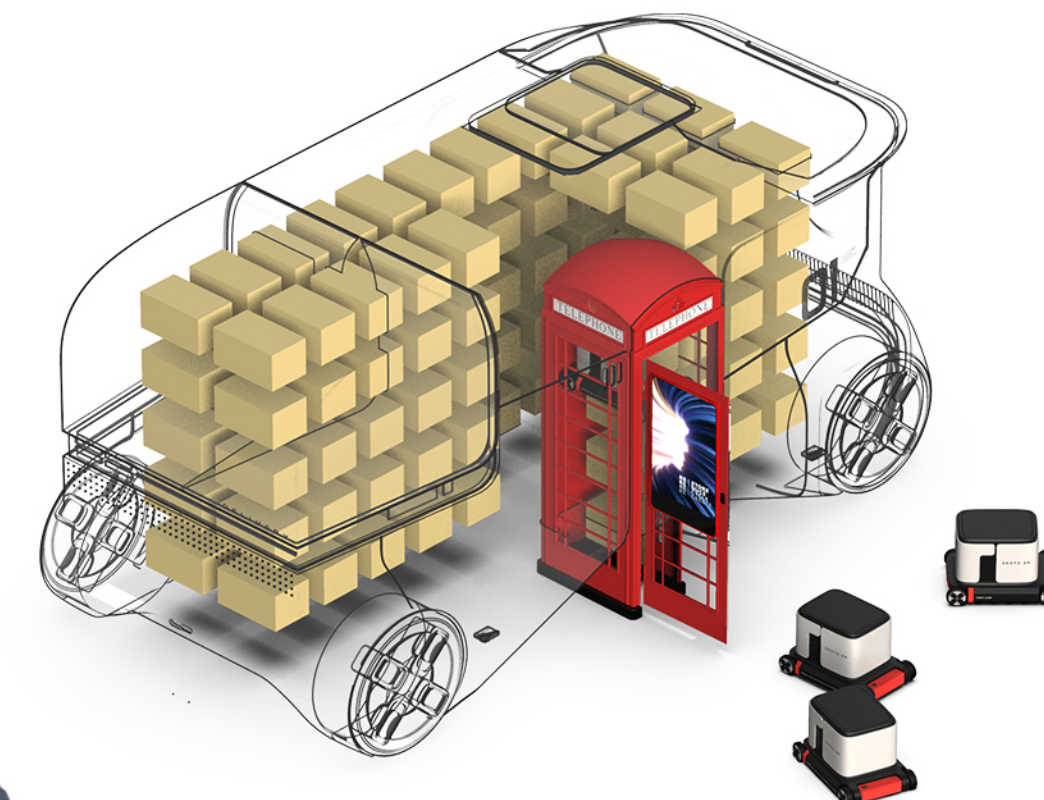
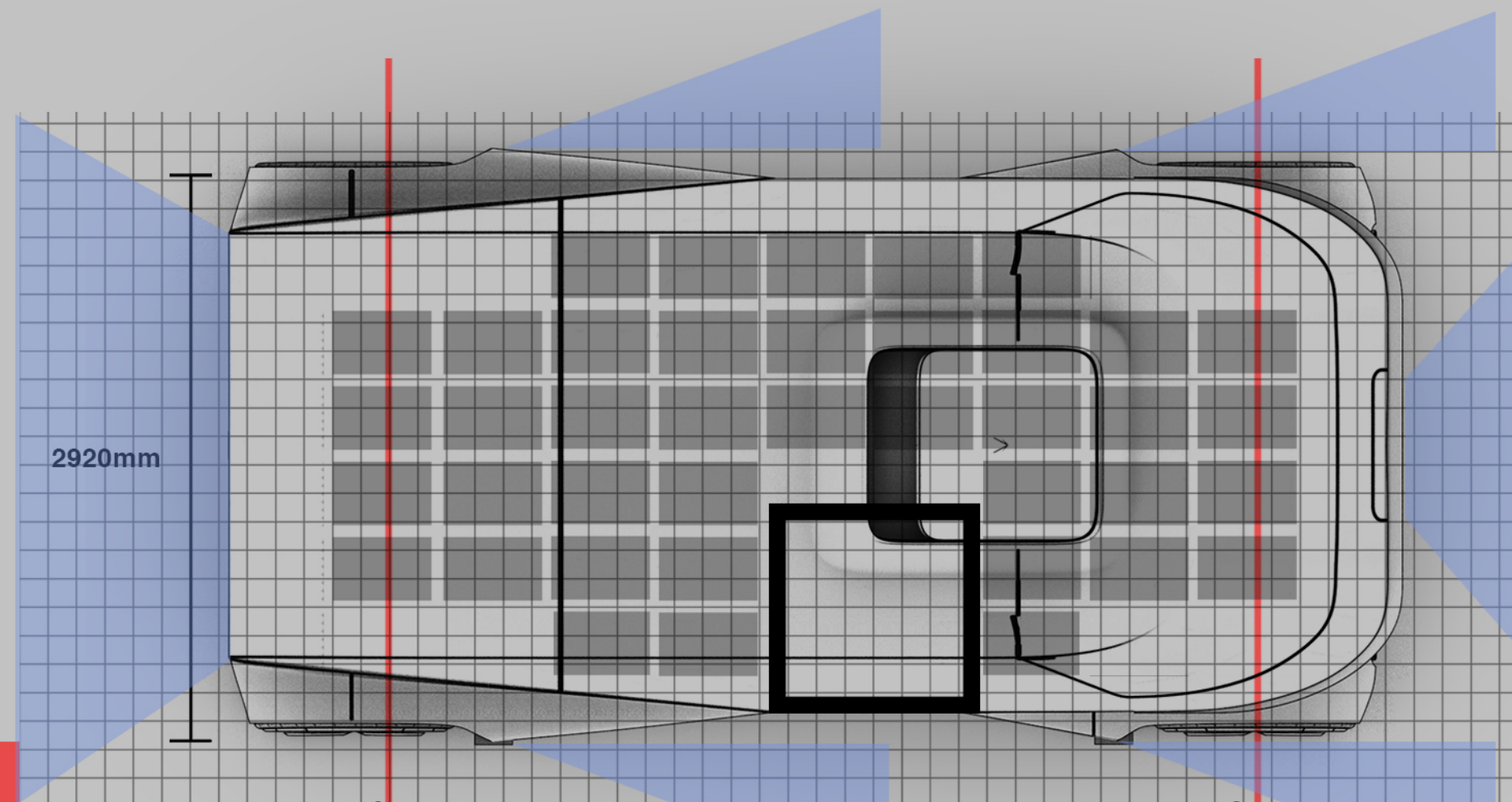

Front view

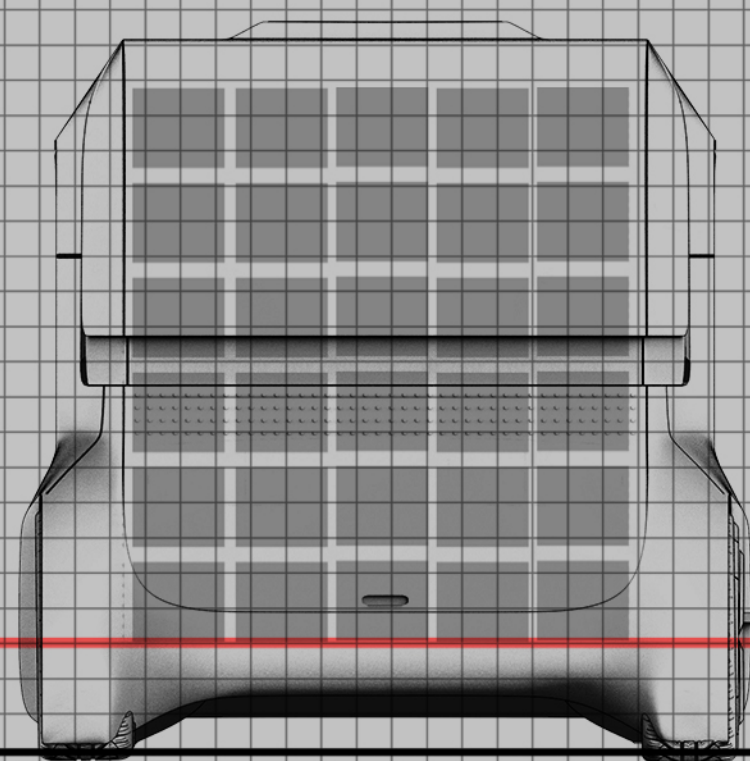

Side view

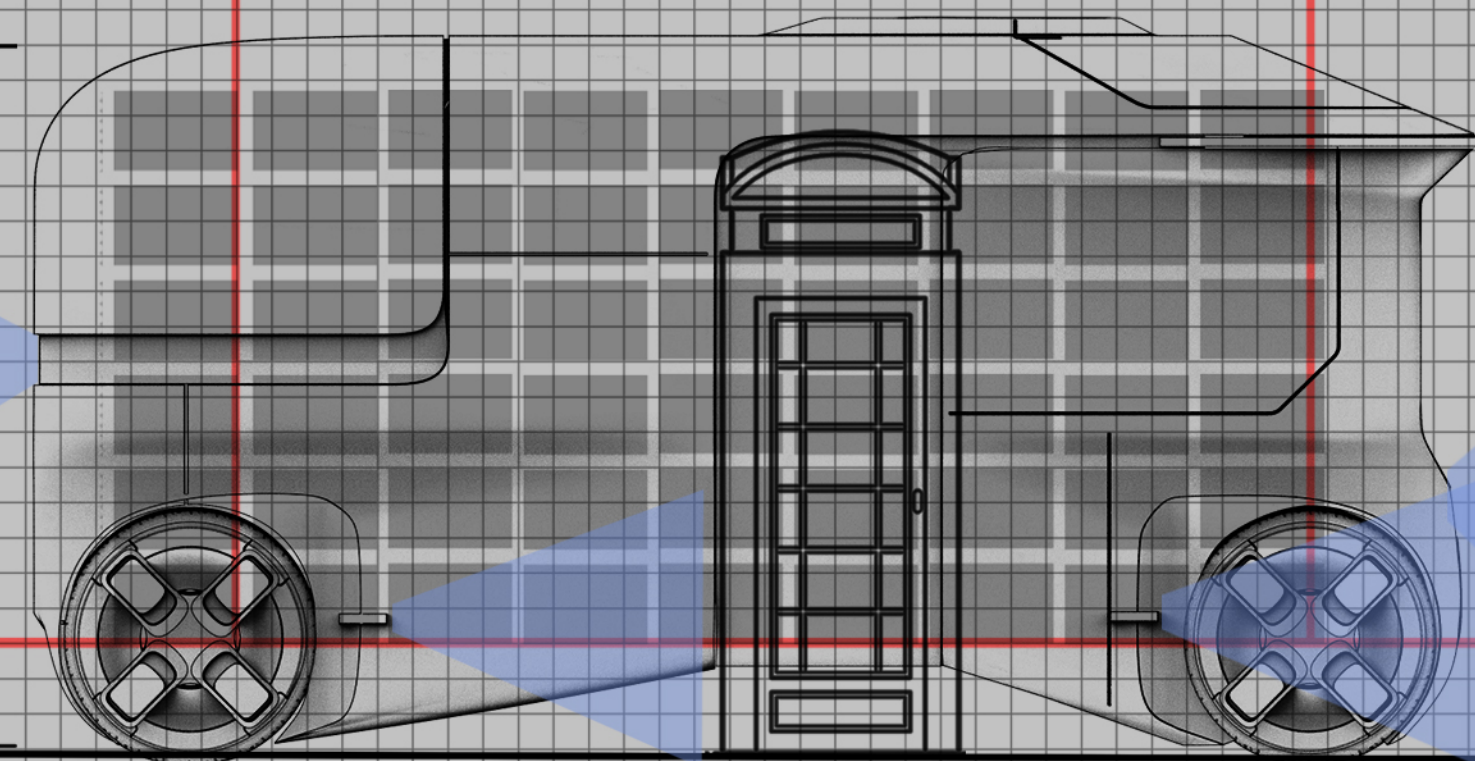

Rear view

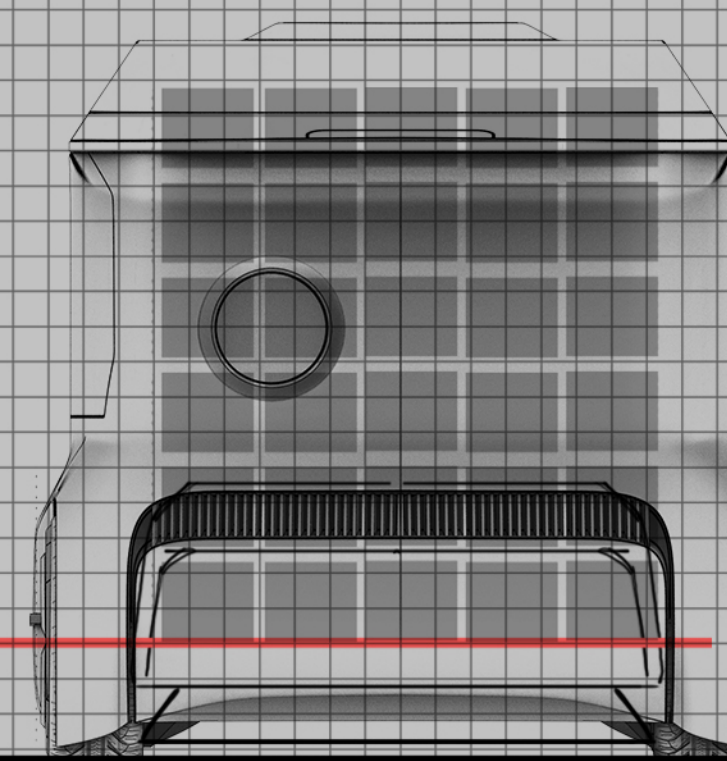



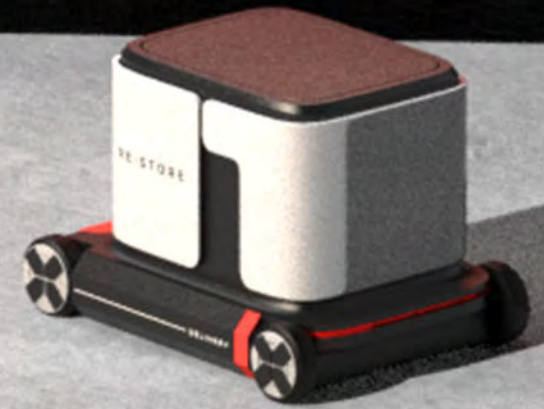

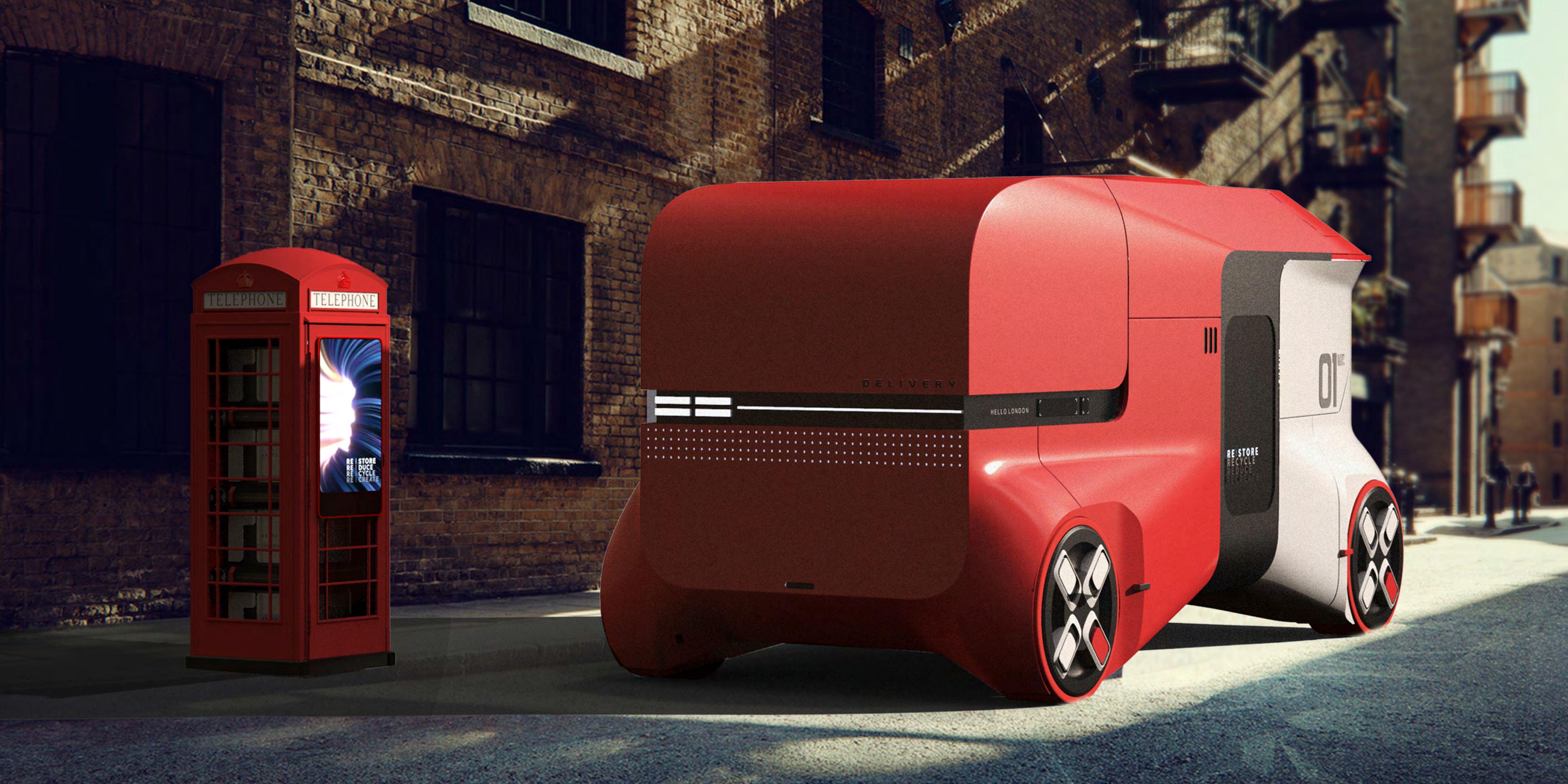

TELEPHONE

TELEPHONE



RE STORE
RE DUCE
RE CYCLE
RE CREATE

DELIVERY

HELLO LONDON

01

RE STORE
RE DUCE
RE CYCLE
RE CREATE

Animation link



<https://www.youtube.com/watch?v=ejXHUTBwDss>

**8:1 Scale model
making process**



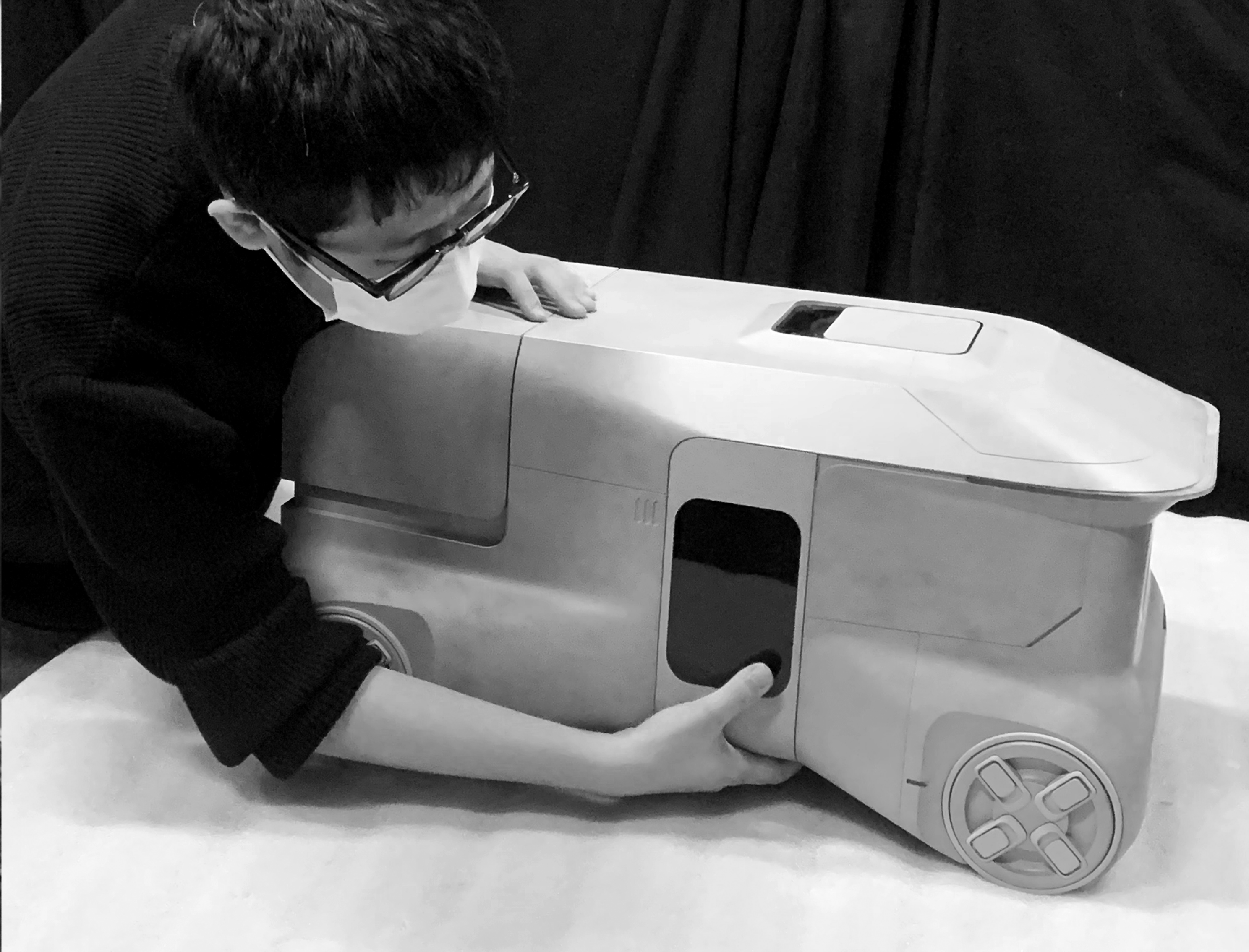





THANK YOU

